

FILTER ELEMENT 37° REVERSE FLARE

51642- -

⑤	⑥					EFF. AREA SQ. IN (MIN)	MIN COLLAPES PRESS
	A	B	C	D	E		
04	1.05	0.359	0.152	0.092	0.136	0.480	1000 PSID
05	2.00	0.421	0.214	0.154	0.199	1.100	875 PSID
06	2.00	0.476	0.274	0.214	0.260	1.350	750 PSID
08	2.00	0.654	0.370	0.310	0.356	2.000	500 PSID
10	2.00	0.767	0.464	0.404	0.450	2.400	200 PSID
12	2.00	0.940	0.589	0.529	0.575	2.750	150 PSID
16	3.50	1.188	0.824	0.764	0.810	6.750	75 PSID

①	MICRONS
005	5
010	10
015	15
020	20
025	25
030	30
035	35
040	40
050	50
060	60
065	65
070	70
075	75
090	90
095	95
100	100
105	105
110	110
115	115
120	120
125	125
150	150
180	180
210	210
250	250
300	300
400	400

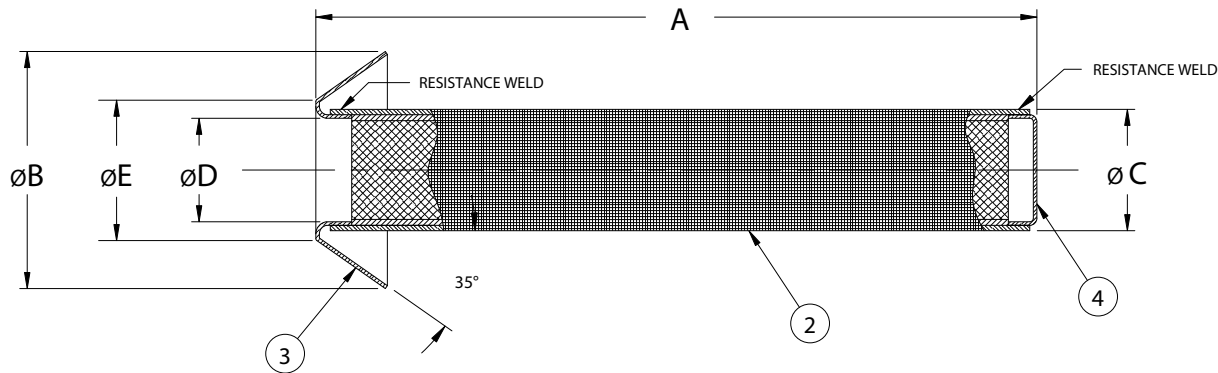

NOTE:

- ① MICRONS BASED ON ABSOLUTE RATING
- ② WOVEN WIRE CLOTH - 300 SERIES CRES
- ③ FLANGE: .010 THICK - 300 SERIES CRES
- ④ END CAP: .010 THICK - 300 SERIES CRES
- ⑤ THESE DASH NUMBERS CORRESPOND TO THE SIZE OF 37° AN FITTING. EXAMPLE: 6 = -6 AN
- ⑥ THE FOLLOWING TOLERANCES APPLY TO THE ITEMS LISTED IN A THRU E: .XX = ±.010
.XXX = ± .005 ANGLES = ±2°